

6

5

4

3

2

1

D

D

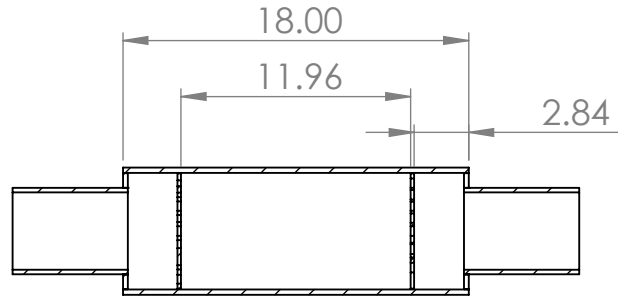
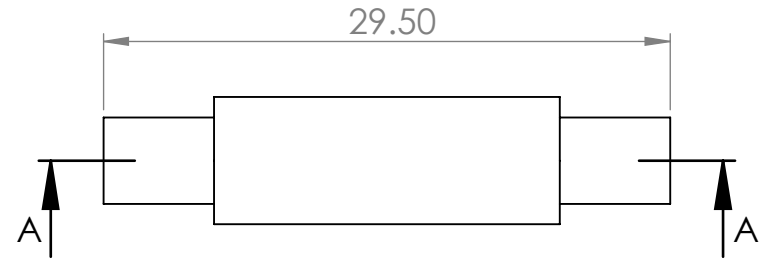
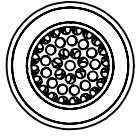

SECTION A-A

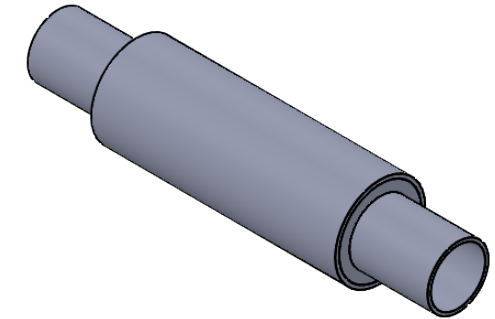

C

C

B

B

6" Schedule 40 Steel Pipe Body  
 4" Schedule 40 Steel pipe Nipples  
 58 catalyst per layer  
 Welded  
 Blasted & Painted Bright Yellow

A

A

UNLESS OTHERWISE SPECIFIED: DIMENSIONS ARE IN INCHES SURFACE FINISH: TOLERANCES: LINEAR: ANGULAR:			FINISH:		DEBURR AND BREAK SHARP EDGES		DO NOT SCALE DRAWING		REVISION					
							Advanced Power Systems, Int'l, Inc.							
							TITLE:  6" X 4" Inline NG FHD 25 Equivent							
							DWG NO.  FHD25-6-4NG				A4			
							WEIGHT:			SCALE:1:10			SHEET 1 OF 1	

6

5

4

3

2

1